

MANUAL AND
SPARE PARTS LIST

GARUDAN[®]

GF-131-443 MH/L34

GF-131-446 MH/L34



ANITA B, s.r.o.

Hliníky 2068

680 01 Boskovice

Czech Republic

tel: +420 516454774, 516453496

fax: + 420 516452751

e-mail: info@anita.cz

www.garudan.cz

MEMO

www.garudan.cz

MEMO

www.garudan.cz

Machine Adjustment

Caution



- ▶ Always turn off the power when mounting a needle.
If the operator mistakenly steps on the pedal while the power is on, the machine will start automatically and can result in physical injuries.
- ▶ When using clutch motor, be aware that the motor will continue to rotate for a while even after the power is switched off due to inertia. Start to work on the sewing machine only after the motor has come to a complete stop.

1) Inserting needle

Move the needle upper end so that it directly touches the upper side of the stopper hole② when the groove① of the needle is on the left. Then, use the clamp screw③ to fix the position of the needle. (Refer to figure 19)

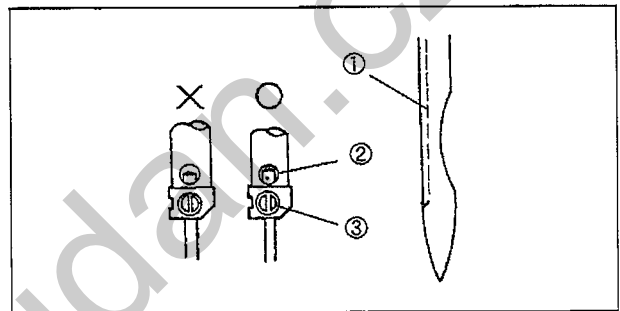

[Figure 19]

2) Adjusting needle bar

Place the needle bar in the lowest position by pulling out the needle bar adjusting hole rubber cover① and rotating the pulley, and then loosen the needle bar holder clamp screw② and move the needle bar such that the needle bar's lowest position mark carved sign④ is aligned with the lower side of the needle bar lower bushing③. After fixing tightly the needle bar holder clamp screw② and place the rubber cover ①.

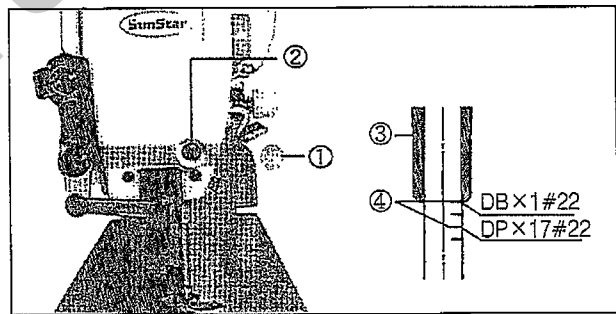

[Figure 20]

3) Adjusting timing of needle and hook

As in Figure 21, align the lower side of the needle bushing ① with the fixed hook position carved line② marked in the needle bar. Then, loosen three hook fixing bolts③. When the hook edge④ is aligned with the center of needle, turn the loosened hook so that the clearance between the needle groove inside carved in the lateral side of the needle and the hook edge④ becomes 0.05~0.1mm. Later, tight again the three fixing bolts③.

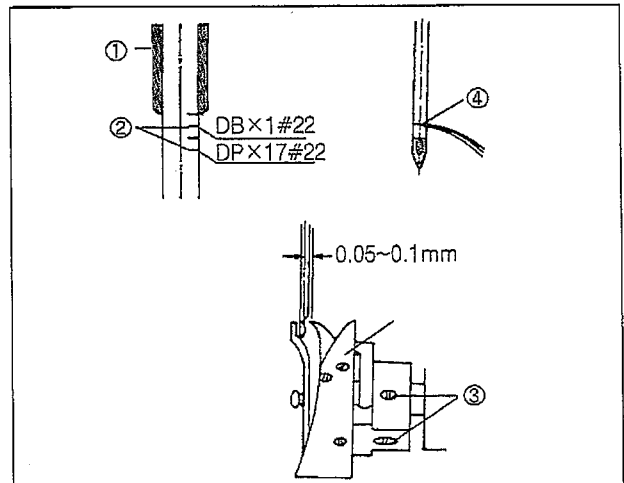

[Figure 21]

4) Adjusting lubrication of thread take-up spring part

As in the figure 22, the more the point② of the control plate of oil flow① goes close to the center of hole of thread take-up crank shaft, the more oil comes. On the other hand, the more the point goes close to the corner⑤ of the link cam washer, the less oil comes.

And when the point goes past the corner of the link cam washer④, the oil does not come out.

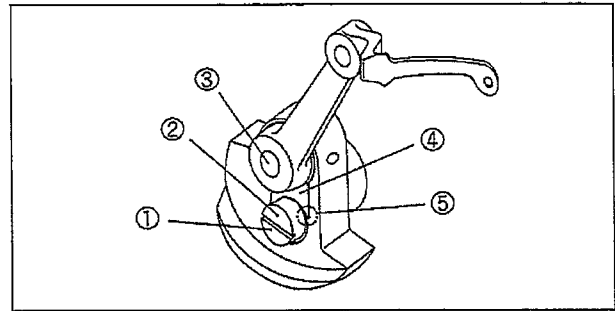

[Figure 22]

5) Adjusting lubrication of hook

A. Confirming the amount of lubrication

a) Perform an idle rotation for about 3 minutes of the machine. Later, place the paper for confirming the amount of lubrication as in Figure 23 and rotate the machine for 5 seconds to confirm the amount of oil sprayed to the paper.

b) Perform 3 times of confirming the amount of lubrication. The adequate adjusted amount is a state where the maximum and minimum amounts do not fall short of or exceed the amount shown in the picture.

(If the amount of lubrication is too small, it could invite the hook seizure, and if the amount is too large, it could cause a contamination by oil.

B. Adjusting the amount of lubrication

When you turn clockwise(+)the lubrication adjustment screw① inserted in the front bushing of the lower shaft, the amount of oil will increase while turning to counterclockwise(-) will decrease the amount.

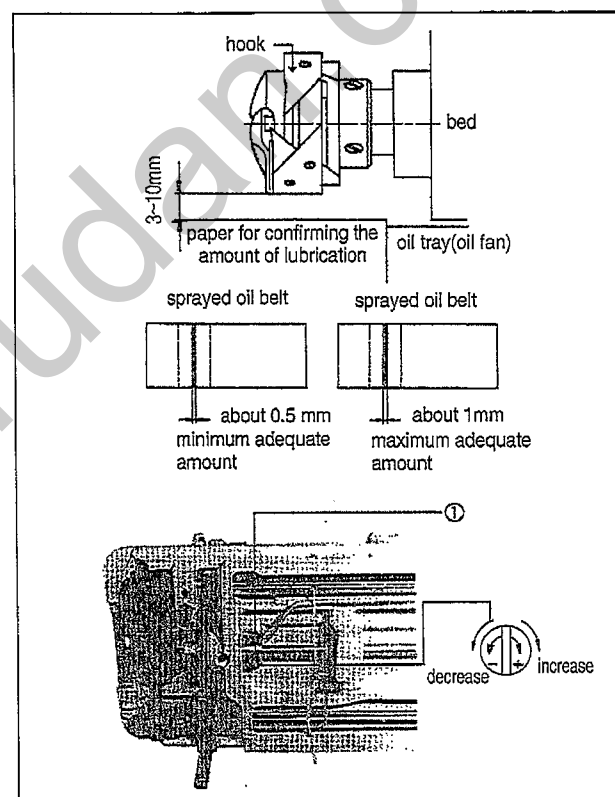

[Figure 23]



Caution



- ▶ Turn off the power when adjusting the lower thread tension.
If the operator mistakenly steps down on the pedal while switched on, the machine will start automatically and can cause physical injuries.
- ▶ When using the clutch motor, be aware that the motor will continue to rotate for a while after the power is switched off. Start to work only after the motor has come to a complete stop.

6) Winding and adjusting lower thread

A. Winding lower thread

- a) Pass the thread thru the hole① from the rear to the frontal side of the tension adjusting dish②.
- b) Bring the thread to the bobbin③ and wind it clockwise 5 to 6 times from the bottom.
- c) Push the lever④ so that the pulley⑤ touches the V-belt and run the machine.
- d) The pulley⑤ automatically is separated from the V-belt when the lower thread is wound in the bobbin.
- e) The adequate amount of the pulled-out lower thread is about 80%. (Refer to Figure 24)

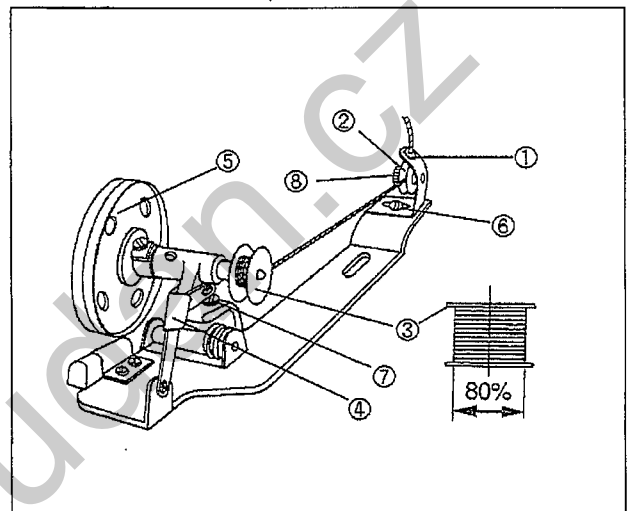

[Figure 24]

B. Adjustment of winding lower thread

- a) In case that the lower thread is wound irregular, loosen the bolt⑥ and adjust by moving it sideways, and tight it again.
- b) The amount of wound lower thread becomes larger when you turn adjusting screw⑦ clockwise, and it becomes smaller in case of turning it counterclockwise.
- c) The tension of lower thread that wound in the bobbin can be adjusted by turning the nut⑧: it increases with clockwise turning and it decreases when you turn counterclockwise.

7) Inserting and removing lower thread and adjusting tension

- A. Insert the bobbin into the bobbin case. Later, insert the thread into the thread groove③ and place it under the spring④ of thread adjusting plate. The tension of the lower thread becomes larger when you turn clockwise the tension adjustment screw⑤ and becomes smaller when you turn in counterclockwise. When hold the end of thread, make sure that the bobbin case⑥ should drop by gravity in order to adjust the lower thread tension.

B. Inserting and removing the bobbin case

Insert into the hook by grabbing the bobbin case handle①. Pull out the handle① when you remove the bobbin. (The bobbin② removes itself when you release the handle.)

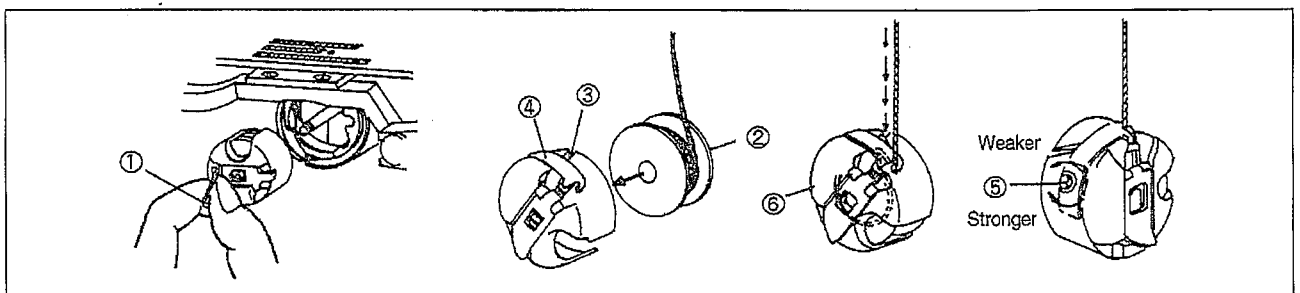

[Figure 25]

Caution



- ▶ Turn off the power switch when routing the upper thread.
If the operator mistakenly presses down on the pedal while switched on, the machine will start automatically and can cause physical injuries.
- ▶ When using the clutch motor, be aware that the motor will continue to rotate for a while after the power is switched off.
Start to work on the sewing machine only after the motor has come to a complete stop.

8) Routing upper thread

Put the thread take-up lever in the highest position and insert the upper thread as shown in the Figure 26 by numerical order.

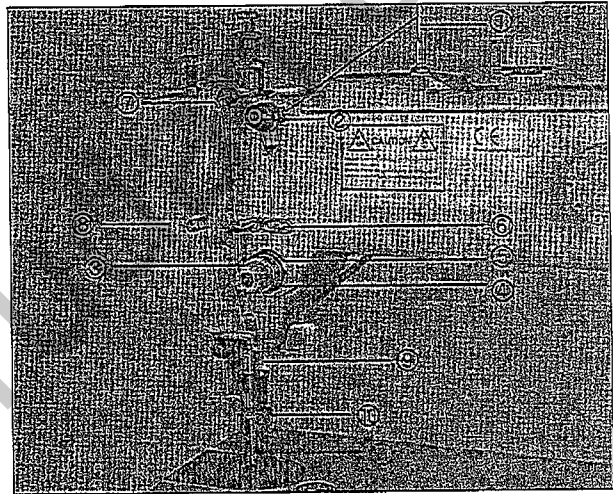

[Figure 26]

9) Adjusting upper thread

A. Thread control assembly

Like in Figure 27, turning the tension adjustment nut ① of the thread tension control assembly clockwise makes the upper thread tension stronger and counterclockwise makes it weaker. The result of the needlework depends on the sewing conditions such as the sewing material, used thread and stitch length. So please adjust as desired.

B. Adjusting the thread take up tension

As in Figure 27, insert the driver into the groove ② of the thread tension control assembly. Turn clockwise to make the spring tension stronger and counter clockwise to make it weaker.

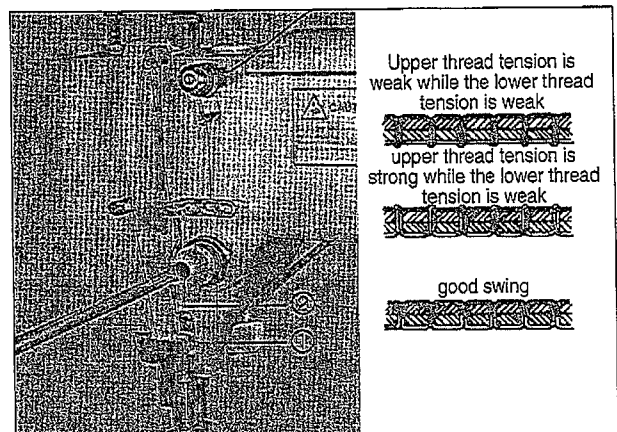

[Figure 27]

Caution



- ▶ After disassembling and adjusting a safety device, always place it back to the original position and check whether it functions as intended.
- ▶ Use both hands when pushing the machine backward or returning it to the original position. Due to the weight of the machine, your hand can get stuck in the machine if you should slip.
- ▶ When adjusting the machine with the switch on, be sure to pay extreme caution.



- ▶ Only trained engineers must perform troubleshooting or inspection of the machine.
- ▶ For electrical repair or inspection, consult with qualified technicians or agent.

10) Adjusting presser foot pressure

As shown in Figure 28, the pressure of the upper feed presser foot becomes stronger when you turn the pressure adjustment screw① clockwise, and becomes weaker in case of turning it counterclockwise.

After the adjustment, be sure to tight the fixing nut②.

The auxiliary presser foot is same to the upper feed presser foot: the pressure increases when you turn the pressure adjustment screw③ clockwise, and becomes weaker in case of turning it counter clockwise.

After the adjustment, be sure to tight the fixing nut④.

In case of fine adjustment, use the auxiliary pressure adjustment screw⑤.

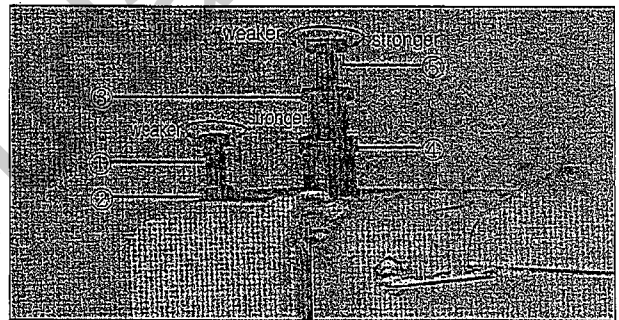

[Figure 28]

11) Adjusting stitch length

As shown in Figure 29, the number marked in the stitch control dial① means the stitch width in mm. Adjust it in sideways and fix it to your desired number of stitch width.

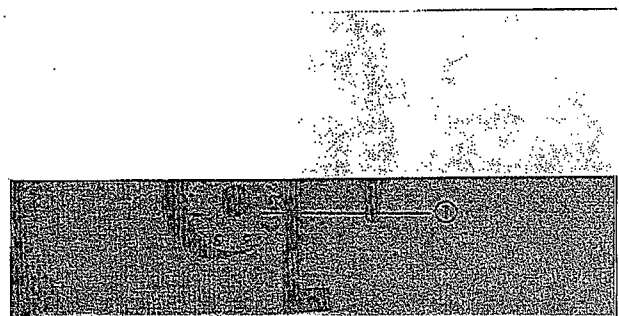

[Figure 29]

12) Adjusting feed dog height and inclination

- A. Adjust the height of the feed dog^③ by loosening the clamp screw^② of the leverage crank(front) and moving the leverage crank(front)^①.
The adequate height from the upper side of needle plate to the end of feed dog is from 1.0mm to 1.2mm when the feed dog is in the highest point with the stitch is put to the maximum level.
- B. To adjust the inclination of the feed dog, loosen the fixing screw of feed dog inclination adjustment crank^⑥ in the horizontal pushing crank^④ first. Later, adjust it by rotating until 90 degree the feed dog inclination adjustment shaft^⑤.
When you turn the shaft^⑤ clockwise, the front of feed dog goes up while the rear part of the feed dog is up with counter clockwise direction.
- C. Check the height of feed dog^③ because the height of it changes after the adjustment of feed dog^③.

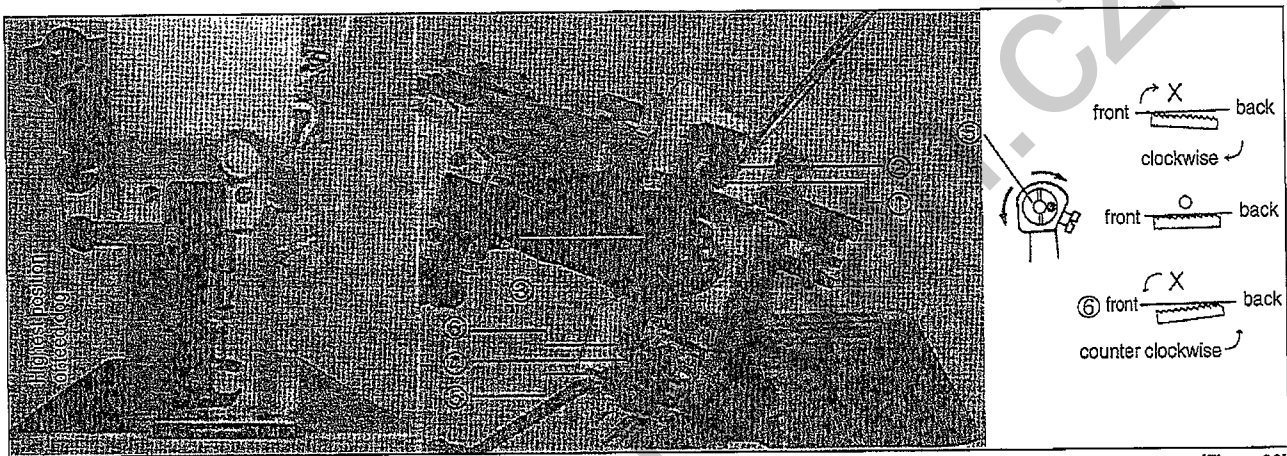

[Figure 30]

13) Adjusting auxiliary presser foot and upper feed presser foot

Normally, the auxiliary presser foot and the upper feed presser foot work vertically with a same height difference.

In accordance with the material type, there are some cases in which run the auxiliary presser foot^① and the upper feed presser foot^② at the same pace, or sometimes, at different paces. In these cases, please adjust the height as follows:

- In case of running vertically the auxiliary presser foot and the upper feed presser foot at the same height

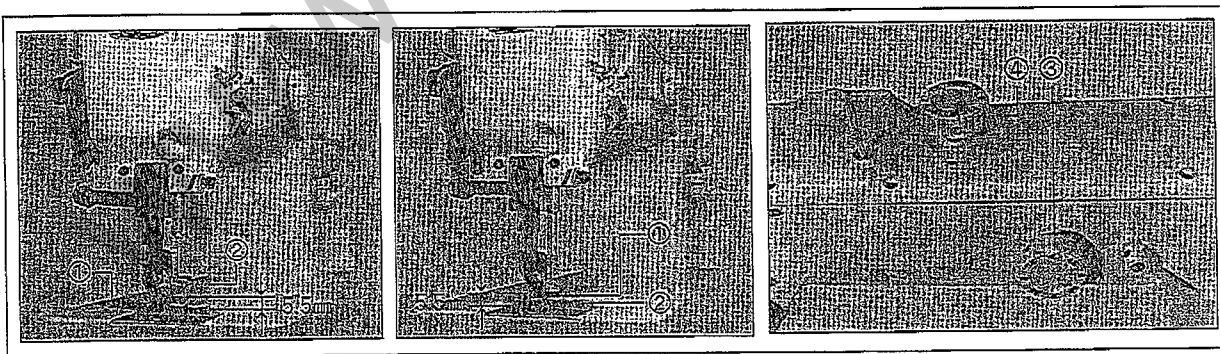

[Figure 31]

- a) The vertical running range of the auxiliary presser foot^① and the upper feed presser foot^② is from 2 to 5.5 mm.
- b) The vertical running amounts of the auxiliary presser foot^① and the upper feed presser foot^② are easily adjustable from the climb device dial attached to the front side of the machine.
- c) The dial^④ attached to the upper cover is a dial which controls the running amount dial^③. Only when the numbers of ^③ and ^④ are identical, the auxiliary presser foot and the upper feed presser foot can be run at the same height.
- ex) When the running amount of the two presser feet are adjusted to 4mm

First, adjust the number of the dial attached to the upper cover to 4, and make the number the dial at front side of the machine 4. When you adjust the number from lower one to a higher, you should adjust the dial^④ first. In the reverse case, the adjustment of the dial^③ should be done first.

15) Adjusting feed cam

The timing of the feed dog and the needle is determined by moving vertically the feed cam④. First, turn the pulley with hands to fix the needle bar to the highest point. The standard position will be when the center of the No. 1 fixing bolt② of the presser foot vertical move cam① is aligned with the center line of the upper shaft③, the bottom of the No. 1 fixing bolt⑤ of the feed cam④ is aligned with the center line of the upper shaft③.

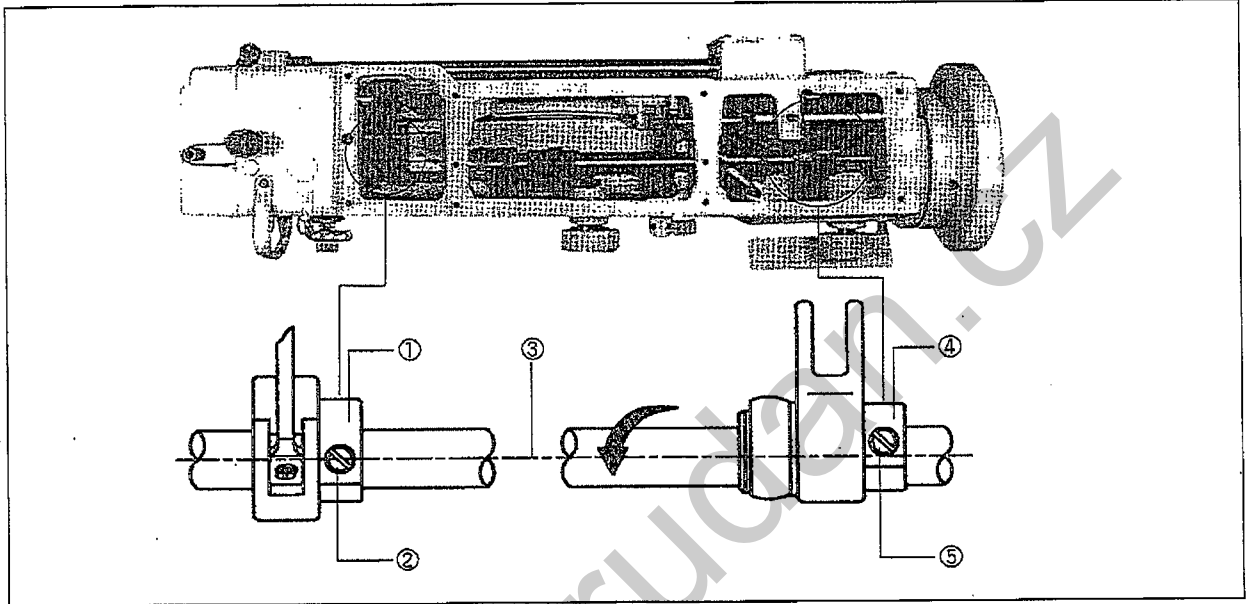

[Figure 34]

16) Adjusting for thread trimmer

A. Structure of thread trimmer

The structure of the thread trimmer of this machine is as follows in Figure 35:

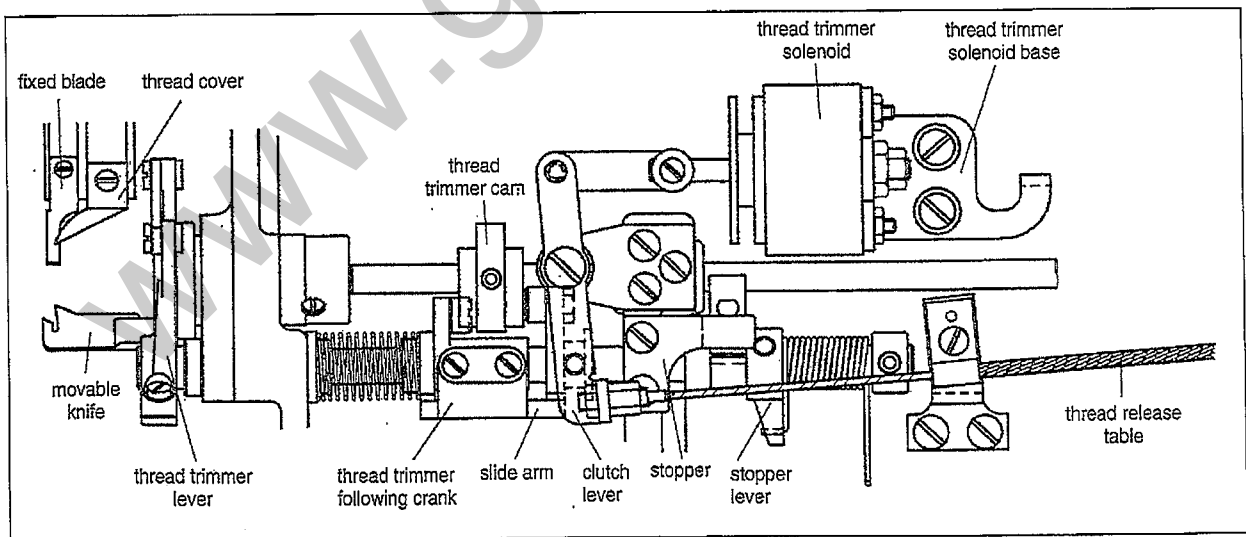

[Figure 35]

(Caution)

This sewing machine is run by the thread trimming driving method, which uses the cam attached to the lower shaft as driving force. Thus, if you rotate the machine with the thread trimming solenoid is in operation in time of the machine adjustment, the moving knife collides with the needle causing harms on the both parts. So, when you run the machine with the solenoid in operation, run only in the regular thread trimming course (down stop ~ up-stop of the needle bar).

- In case of running the auxiliary presser foot and the upper feed presser foot at different heights

A. Adjusting the auxiliary presser foot

- Loosen the presser bar pressure adjustment screw① and the bracket fixing screw②.
- Adjust vertically the bracket fixing screw② so that the auxiliary presser foot④ goes up by 8mm from the upper side of the needle plate when the presser bar lifter③ is up.
- When the adjustment is finished, fix tightly the bracket fixing screw② and adjust adequately the pressure adjustment screw①.
- After adjust height of the auxiliary presser foot④, adjust upper feed presser foot.

B. Adjusting the upper feed presser foot

- Place the thread take up at the lowest position and lower the presser bar lifter③.
- Open the rubber cover⑤ of the upper cover and loosen the clamp screw⑥.
- A different adjustment of vertical running amount between the auxiliary presser foot④ and the upper feed presser foot⑧ is possible by adjusting the presser foot vertical move crank⑦.
- When the adjustment is finished, fix tightly the clamp screw⑥ of the vertical move crank, and place the rubber cover⑤.

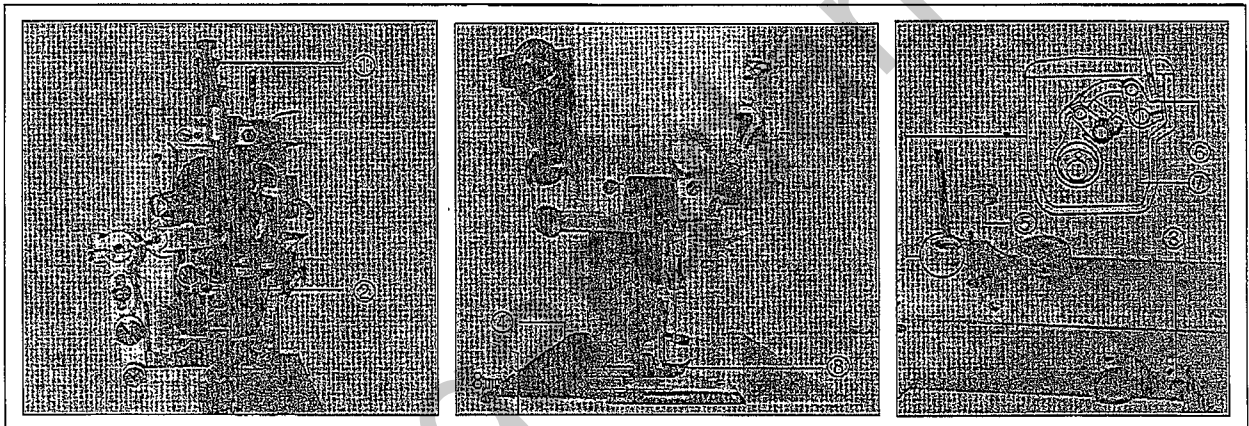

[Figure 32]

14) Adjusting feeding amount of auxiliary presser foot

The normal proportion of feeding amount between the feed dog and the auxiliary presser foot is 1:1. You can adjust the feeding amount of the auxiliary presser foot in accordance with the conditions of materials in use. As in Figure 33, loosen the nut① and move upward the presser foot vertical move control shaft②, and the feeding amount becomes smaller. If you move it downward, the amount increases. Be sure to tight the nut① when the adjustment is finished.

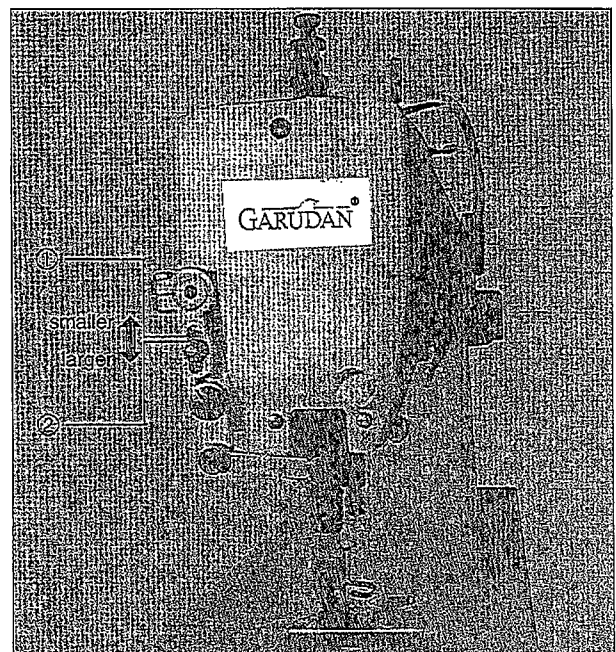

[Figure 33]

B. Adjusting fixing blade and movable knife

- a) Like in Figure 36, the standard position is where the cut part of the movable knife is aligned with the center of the fixed blade.
- b) When part ② becomes bigger in Figure 36, three pieces of threads are to be produced, causing the thread missing after the trimming. If part ③ becomes bigger, it can cause a trimming miss. So be cautious in adjusting the right position.

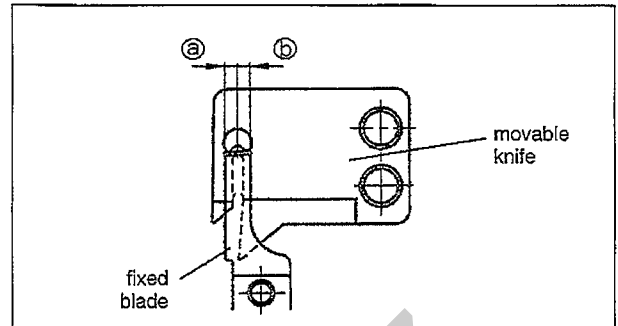

[Figure 36]

C. Adjusting the trimmer driving part

- a) The standard assembly position is shown in Figure 37.
- b) Fix the thread trimming following crank to the trimming shaft as shown in the figure.
- c) Fix the stopper lever to the bed so that the lever can smoothly rotate in a range where the gap of the trimming shaft does not occur.

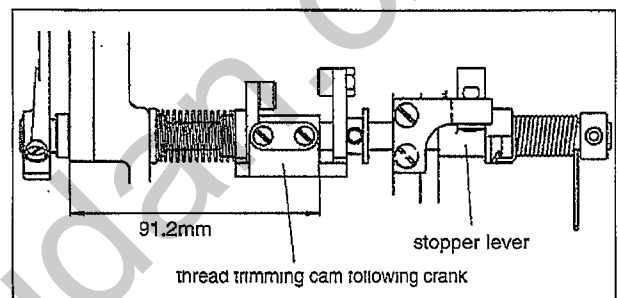

[Figure 37]

D. Adjusting the thread trimmer solenoid

- a) Working amount of the thread trimming solenoid
 - ① The standard working amount of the thread trimming solenoid is 4.6mm as shown in Figure 38.
 - ② Use the thread trimming solenoid stopper nut to control the working amount.

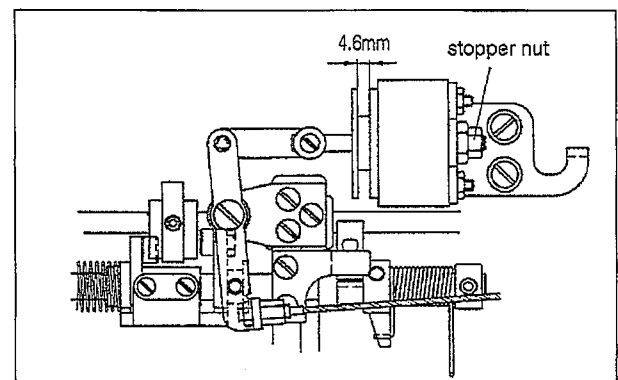

[Figure 38]

b) Adjusting the thread trimming solenoid

- ① First, loosen the solenoid link pin fixing screw. Later, fix the solenoid base clamp screw where the clutch lever moves smoothly. Then, attach the slide arm to the right side. Fix the thread trimming solenoid link pin fixing screw where the solenoid stopper is attached to the solenoid.
- ② If you run the solenoid under this circumstance, a gap of 0.5mm occurs between the thread trimming following crank and the slide arm as shown in Figure 39. This state is the standard.

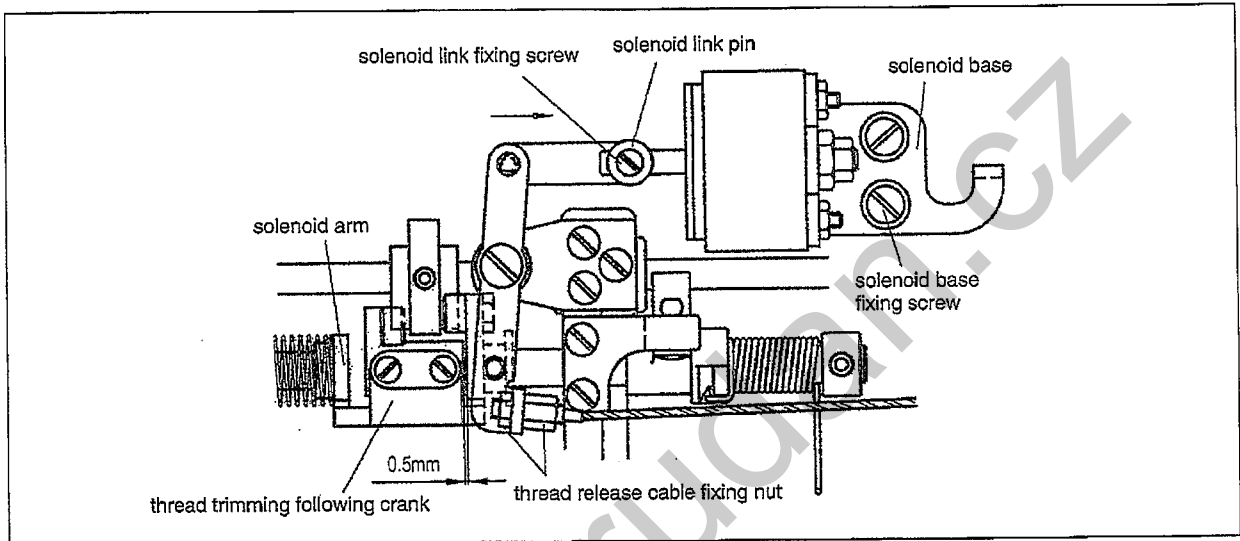

[Figure 39]

E. Adjusting the thread trimming cam

- a) Like in Figure 40, align the second timing carved line (Green) of the pulley with the arm's carved line.

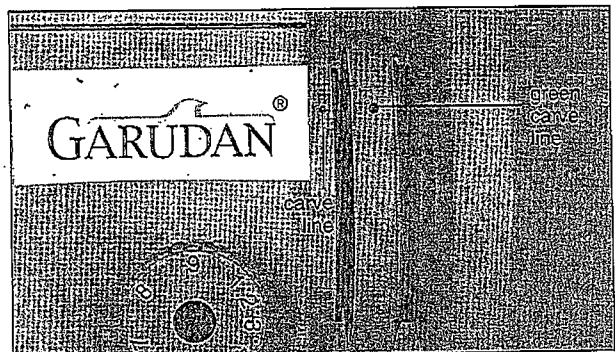

[Figure 40]

- b) Under the thread trimming solenoid is in operation, rotate the trimming cam clockwise and fix the cam when it is connected with the roller. (Refer to Figure 41)
- c) When the thread cam following crank returned by stopping the operation of the thread trimming solenoid, the edge end between the cam and the roller should be from 0.5 to 1.0mm. It is the standard. (Refer to Figure 40)

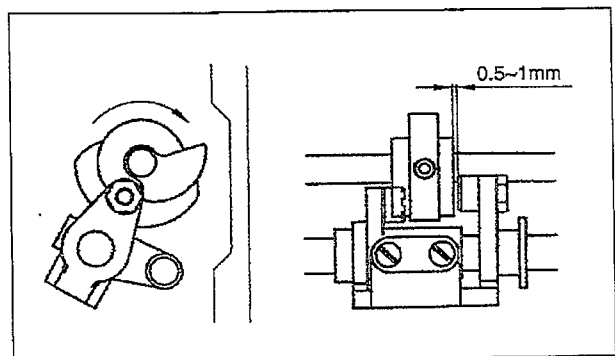

[Figure 41]

(Caution)

The standard position of the thread trimming cam following crank before its operation is shown in Figure 42. If the position of the roller is changed, adjust it with stopper and perform the adjustment describe above in a~b.

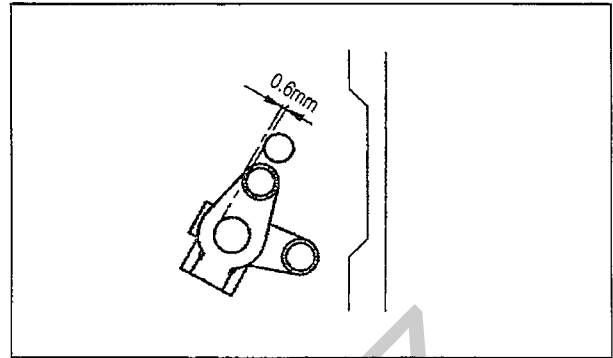

[Figure 42]

F. Adjusting the position of blade

- a) Adjusting the position of the movable knife and the fixed blade

The standard position of the movable knife is 7.5mm from the needle center, and 5 mm for the fixed blade.

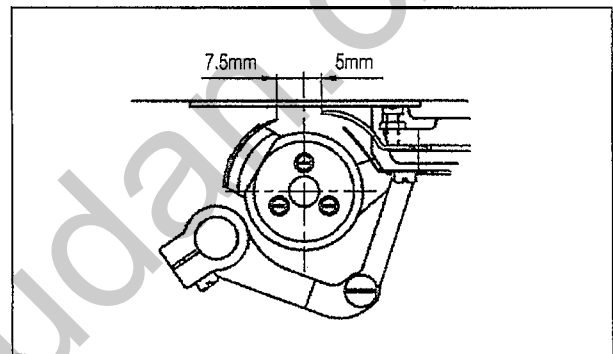

[Figure 43]

- b) Adjusting the progress amount of the movable knife

- ① If you run the machine putting the solenoid in the operation mode, the movable knife will rotate by the thread trimming cam. The standard will be where the cut part of the movable knife progresses 1.5 to 2mm from the end edge of the fixed blade when the progress amount of the movable knife is in its maximum.
- ② Adjustment is available by using the thread trimming lever.

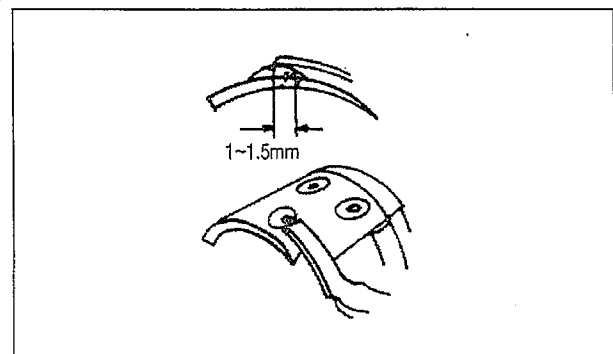

[Figure 44]

17) Adjusting blade pressure

- A. As in Figure 45, the standard is when the contact between the movable knife and the fixed blade begins.
- B. In particular, when the cutting quality gets worse by using a thick thread, strengthen a little bit the tension of the fixed blade.

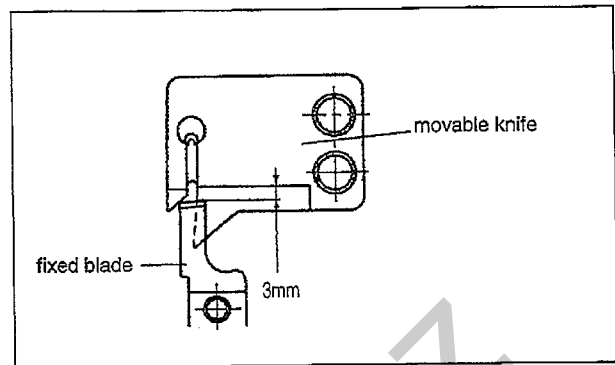

[Figure 45]

- C. In order to adjust the tension of the fixed blade, loosen the tension adjustment nut with the wrench box and adjust the tension using the tension adjustment bolt.

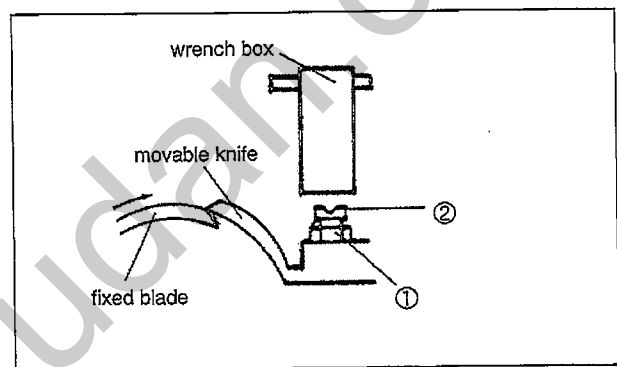

[Figure 46]

18) Exchanging movable knife

To exchange the movable knife, turn the pulley with hands such that the needle can be located in the highest position and separate the needle plate. And, loosen the two fixing bolts of movable knife shown in Figure 47 and break it up. In case of assembling the exchanged part, please perform this in a reverse manner.

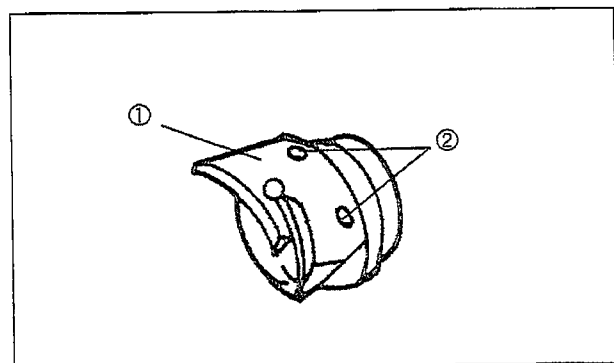

[Figure 47]

19) Exchanging fixed blade

- A. When you exchange the fixed blade, loosen first the inside stopper clamp screw to get the washer and inside stopper and disassemble by loosening the fixed blade clamp screw. In case of assembling the exchanged part, please perform this in a reverse manner.

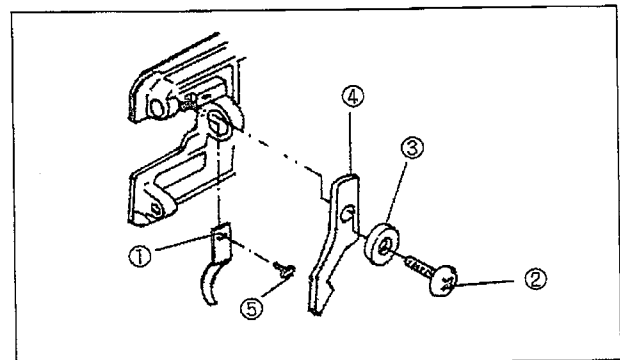

[Figure 48]

- B. In case that the thread is cut or the cut part of the thread is not neat, please confirm the cutting part of the fixed blade. If the bottom of the fixed blade is worn, sharpen the end of the blade using an oil whetstone.

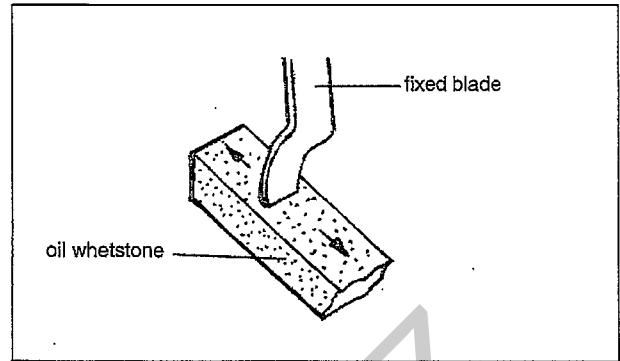

[Figure 49]

20) Adjusting thread release

- A. Adjust such that the dish of upper thread tension controller opens about 1mm when the thread trimming solenoid is in the operation.
- B. Adjustment is available by loosening the thread release cable fixing nut and wire. (Refer to Figure 50)

(Caution)

If the gap of the control dish is too narrow, it invites the shortening of the upper thread causing a possible thread missing in the next work. If the gap is too wide, a bad thread tightening caused because the dish will be always open.

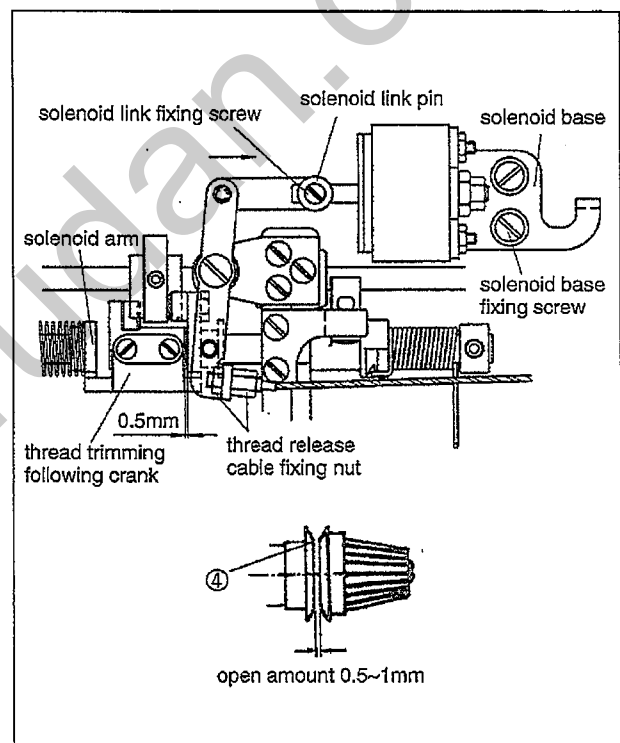

[Figure 50]

21) Adjusting remaining amount of upper thread

Adjust the remaining amount of upper thread is adjustable with the auxiliary thread tension adjusting nut. The remaining thread becomes shorter when you turn it right, and the thread becomes longer if you turn left. (Refer to Figure 51)

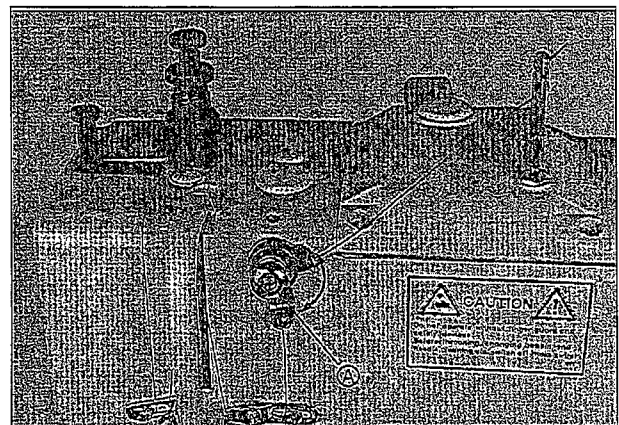

[Figure 51]

4

Causes of Troubles and Troubleshooting

1) Sewing machine troubleshooting

No.	Symptom	Checkpoints	Root cause	Corrective action
1	Needle breaks	Direction and height of needle	Needle is inserted into wrong position	Reinsert the needle correctly
		Needle	Needle is bent	Change the needle
		Timing of feed dog	Bad timing of feed dog	Adjust the timing of feed dog
		Ascending level of needle bar	Bad timing of needle and hook	Adjust the timing of needle and hook
		Height of needle	Bad timing of needle and hook	Adjust the timing of needle and hook
		Gap between needle and hook	Bad timing of needle and hook	Adjust the timing of needle and hook
2	Thread breaks	Threading method	Wrong threading	Thread the needle correctly
		Needle	Bent needle or broken needle tip	Change the needle
		Direction and height of needle	Needle inserted in the wrong position	Insert the needle correctly
		Upper thread tension	Too tight upper thread tension	Reduce tension of upper thread
		Lower thread tension	Too tight lower thread tension	Reduce tension of lower thread
		Working capacity of take-up lever spring	Loose upper thread	Adjust take-up lever spring
3	Poor thread adjustment	Thread tension	Upper and lower thread tensions are bad	Adjust the upper and lower thread tensions
		Thread take up spring tension	Thread take up spring tension is inadequate	Adjust the thread take up spring tension
		Gap between opener and hook	The gap between the opener and hook is inadequate	Adjust the gap between the opener and hook
4	Upper thread falls out when starting to sew or sewing is skipped.	Direction and height of needle	Needle is inserted into wrong position	Reinsert the needle correctly and push in to its highest level.
		Needle	Needle is bent	Change the needle
		Threading	Wrong direction	Insert the thread in the right way.
		Gap between the needle and the hook	The timing between the needle and hook is bad	Adjust the timing between the needle and hook
		Remaining upper thread length after trimming	The length of the remaining upper thread is too short	Increase the adjustment volume of the upper thread on the control box
		Lower thread holder	After trimming, lower thread holder does not hold the lower thread	Adjust the location and tension of the lower thread holder.
		Check the up-stop position of the needle	Due to problems in the up-stop position of the needle, the thread take up lever pulls the upper thread out of the needle when the sewing starts	Readjust the needle's up-stop film position
5	Trimming miss	The gap between the movable knife and the hook	The height and distance between the movable knife and the hook do not match	Readjust the movable knife setting position
		Check the tension of fixed knife	Tension and contact of movable and fixed knives are bad	Correct the tension adjustment and surface contact of movable and fixed knives.
		Direction of the needle	Needle is not inserted correctly	Insert the needle correctly
		Blade side of movable and fixed knives	Scratch and abrasion of movable and fixed knives	Replace movable knife or fixed knife.
		Trimming cam timing	The timing of trimming cam is wrong	Adjust the timing of trimming cam
		Thread release stroke	Thread release stroke is too small	Readjust the thread release stroke
6	Too short thread length after trimming	Trimming timing	Wrong trimming timing	Adjust the trimming timing
		Opening of the thread tension adjusting plate	The opening on the thread tension control plate is too small	Adjust the thread release stroke
		Tension of auxiliary thread tension adjustment assembly	Too strong tension on the auxiliary thread tension control assembly	Adjust the tension of the auxiliary thread tension control assembly
		Thread take up stroke	Thread take up stroke is too large	Adjust the thread take up stroke
		Thread release adjustment volume on the control box	Volume is adjusted to too low	Increase the volume adjustment.